

Warranty

Innkeeper LTD is covered by a 2-year warranty to be free from defective workmanship and materials. In the event that the innkeeper LTD needs repair, you must call us to get an authorization, and then carefully pack and ship it to us. You will pay for shipping to us and we will pay for return back to you, UPS ground. No free repairs will be made if the defect was caused by misuse, weather conditions, or other cause, except for defective workmanship or materials.

THERE ARE NO EXPRESSED OR IMPLIED WARRANTIES WHICH EXTEND BEYOND THE WARRANTY HERE MADE.

innkeeper LTD

Digital Hybrid



User Guide

06/09

JK Audio, Inc. 1311 E 6th Street, Sandwich, IL 60548 USA
Voice: (815) 786-2929 Toll Free: 800-JK-Audio Fax: 815-786-8502
info@jkaudio.com www.jkaudio.com
Copyright © 2009 JK Audio. All rights reserved.

JK Audio

Introduction

Innkeeper LTD allows you to send line level signals into the phone line while maintaining excellent separation between your voice and the caller. The balanced XLR output jack contains only the caller's voice, making this the perfect companion to mixers, consoles, and PA systems that demand talk show quality audio from a phone line.

The digital hybrid connects audio signals to a standard analog phone line without the transmit/receive crosstalk common to analog hybrids. Its Digital Signal Processor (DSP) continuously monitors both the phone line and audio signals to deliver excellent separation. This proprietary, dual-convergence echo canceller algorithm can achieve separation typically exceeding 50 dB without any setup and without sending a noise burst down the line. While this may sound complicated, it's all done automatically during every call.

Ready to go?

The innkeeper LTD controls and connectors are clearly marked and ready for operation. The Features, Setup diagrams and Operation sections on the following pages will help you answer any minor questions that you may have. If this is your first exposure to a hybrid, we suggest that you read the entire manual to allow you to take advantage of all these features.

Any Questions?

Before you pick up the phone... Please thumb through the rest of this manual. You might find those deep technical questions are covered on later pages.

FCC Registration (continued)

- b) The telephone equipment's FCC registration number. This can be found on the bottom of your telephone equipment, and,
- c) The ringer equivalence number (REN) for this equipment.

The REN is used to determine the quantity of devices which will be connected to the telephone line. Excessive RENs on the telephone line may result in the devices not ringing in response to an incoming call. In most, but not all areas, the sum of the RENs should not exceed 5.0. To be certain of the number of devices that may be connected to the line, as determined by the total RENs, contact the local telephone company.

3. Repair Instructions

If it is determined that your telephone equipment is malfunctioning, the FCC requires that it not be used and that it be unplugged from the modular outlet until the problem has been corrected. Repairs to this telephone equipment can only be made by the manufacturer or its authorized agents or by others who may be authorized by the FCC. For repair procedures, follow the instructions outlined under the warranty section of the manual.

4. Rights of the telephone company

If telephone equipment is causing harm to the network, the telephone company may temporarily discontinue your telephone service. If possible, they'll notify you before they interrupt service. If advanced notice isn't practical, you'll be notified as soon as possible. You'll be given the opportunity to correct the problem, and you'll be informed of your right to file a complaint with the FCC.

Your telephone company may make changes in its facilities, equipment, operations or procedures that could affect the proper functioning of your JK Audio product. If such changes are planned, you'll be notified by your telephone company.

FCC Part 15 Compliance

This equipment has been tested and found to comply with the limits for a Class A digital device, pursuant to Part 15 of the FCC Rules. These limits are designed to provide reasonable protection against harmful interference when the equipment is operated in a commercial environment. This equipment generates, uses, and can radiate radio frequency energy and, if not installed and used in accordance with the instruction manual, may cause harmful interference to radio communications. Operation of this equipment in a residential area is likely to cause harmful interference in which case the user will be required to correct the interference at his own expense.

Changes or modifications not expressly approved by JK Audio can void the user's authority to operate the equipment.

FCC Registration

Your new JK Audio product has been registered with the Federal Communications Commission (FCC). This product complies with the standards in Part 68 of the FCC rules.

1. Connection and use with the nationwide telephone network

The FCC requires that you connect this telephone equipment to the national telephone network through a USOC RJ-11C modular telephone jack.

This equipment may not be used with Party Line Service or Coin Telephone Lines.

This equipment is hearing aid compatible.

2. Information for the telephone company

Upon request from your local telephone company, you are required to provide the following information:

- a) The "line" to which you will connect the telephone equipment (that is, your telephone number), and

Table of Contents

Introduction	2
Warnings and Safety Precautions	4
Features	
Front View	5
Rear View	6
Connecting Cables	7
Setup diagrams	
Studio Mix-Minus Setup	8-9
Mix-Minus Explanation	10
Simple Mix-Minus Setup	11
PA System Setup	12
Alternative to Mix-Minus Setup	12
Operation	
Auxiliary Telephone	13
Optional Jumper Settings	13
Auto Answer	13
Remote Control Jack	14
Optional Guest Module 1	14
FAQs	15
Specifications	16
Block Diagram	17
FCC Compliance and Registration	18-19
Warranty	20

Warnings and Safety Precautions

1. Read and keep these instructions.
2. Heed all warnings.
3. Follow all instructions.
4. Clean only with a soft dry cloth.
5. Do not install near any heat sources such as radiators, heat registers, stoves, or other apparatus (including amplifiers) that produce heat.
6. Do not defeat the safety purpose of the three-prong grounding-type plug. If the provided plug does not fit into your outlet, consult an electrician for replacement of the obsolete outlet.
7. Do not use this unit if the electrical power cord is frayed or broken. The power cord should be routed so that it is not likely to be walked on or pinched by items placed upon or against it.
8. To reduce the risk of fire or electric shock, do not expose this apparatus to rain or moisture.
9. Refer all servicing to qualified service personnel.
10. The following warning symbol may be used elsewhere in this manual:



The exclamation point within an equilateral triangle is intended to alert the user of the presence of important operating and maintenance (servicing) instructions in the user guide.

Block Diagram

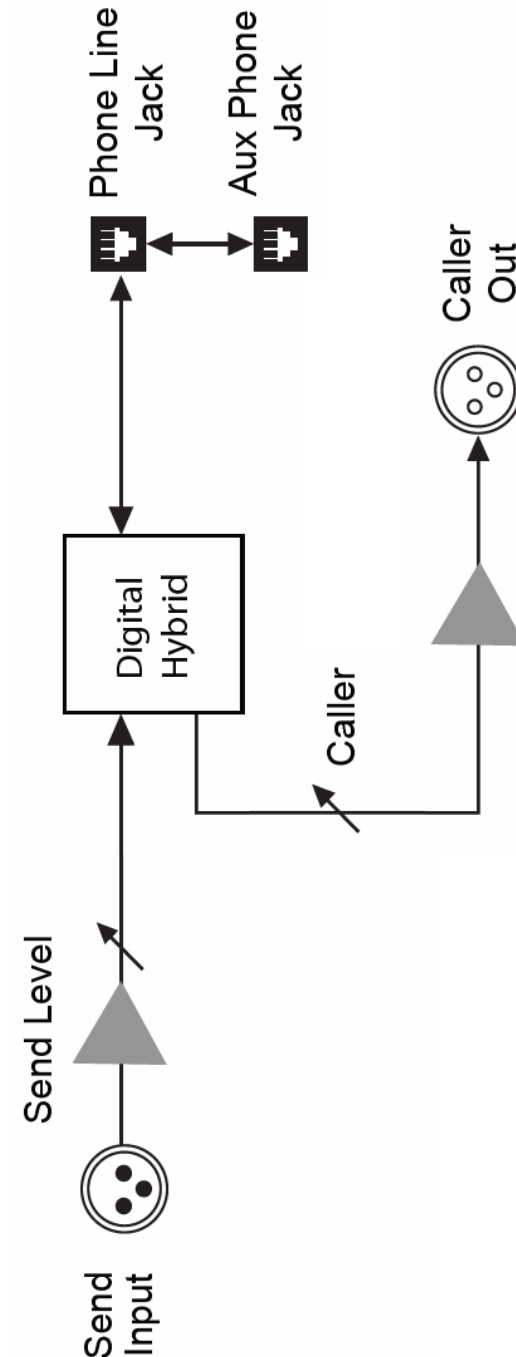

Figure 6: Block Diagram

Specifications

Input

Send: Balanced Female XLR, 20k ohms,
500 mV RMS (-4 dBu nom.)

Output

Caller: Balanced Male XLR, 200 ohms,
500 mV RMS, -4 dBu nom, +14 dBu Max.

Remote Jack: RJ-45

Phone Line Jack: RJ-11C

Isolation: 1500 VAC

Ringer: 0.8B REN

Frequency Response: Telephone side 200 Hz - 3600 Hz

Power: 120-240 VAC power supply (included)

Size: 7.6" x 5.3" x 1.5" (20 x 14 x 4 cm)

Weight: 2.7 pounds (1.2 kg)

Features—Front View

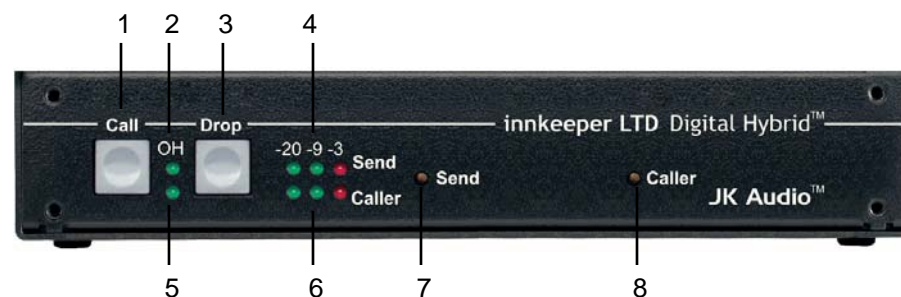

Figure 1: Front View

1. **Call Button** - Takes the phone line off hook - press this button to answer a call or to direct a call from your phone through the hybrid.
2. **OH LED** - Lit when you are on line with a call (off-hook). LED will flicker when you have an incoming call.
3. **Drop Button** - Press this button to drop (hang up) a call.
4. **Send LEDs** - Indicate the signal level going out to the phone line.
5. **Power LED** - Indicates that the unit is receiving power.
6. **Caller LEDs** - Indicate the signal level coming in from the phone line, after the DSP.
7. **Send Level** - Recessed volume control adjusts the signal that you are sending down the telephone line.
8. **Caller Level** - Recessed volume control adjusts the level of the signal coming in from the telephone line, going out the "Caller" XLR jack.

Features—Rear View



Figure 2: Back View

9. **Phone Line** - Connect only to a standard, single line, analog telephone line.
10. **Aux. Phone** - Connect a single line analog telephone for call setup / dialing, or producer call screening.
11. **Auto Answer** - This button enables innkeeper LTD to automatically answer an incoming call and then disconnect after the caller hangs up. Auto Answer will occur on the first ring.
12. **Caller Output** - Male balanced XLR line level output contains only the caller's voice.
13. **Send Input** - Female balanced XLR line level input for signals going out to the phone line.
14. **Remote Control Jack** - 8-pin modular RJ-45 jack for connection to the optional JK Audio Guest Module 1 Remote Keypad or your broadcast console switch contacts. Do not connect this jack to your computer network port.
15. **Power** - For connection only to the supplied 9VDC regulated power supply.

FAQs

- ? **Does the innkeeper LTD send a burst or beep down the phone line at the beginning of each call like our current hybrid?**
- ! No, innkeeper LTD uses the actual transmit signal to evaluate the phone line and tune its algorithm. As you begin to speak, innkeeper LTD is hard at work canceling your voice from the Caller Output jack. Within milliseconds your voice is reduced into the noise floor.
- ? **Can I use the innkeeper LTD on a VoIP line?**
- ! Many VoIP lines have an analog telephone adapter you can connect your telephone to. If you can use any standard analog telephone, then innkeeper LTD should work great. If you have to use a specific telephone, you should consider our PBXport digital hybrid instead.
- ? **The caller's audio is too high and is always distorted even though I have the Caller level control turned down low. What else can I do?**
- ! The Receive LED meter will indicate the level of audio coming in from the telephone line, just after it passes through the DSP. The Caller level control will only set how much of that audio will be sent to the output jack, and will have no effect on the LED meter. If your incoming audio level is unusually hot and already peaking the -3 dB LED, there is a jumper on the circuit board you can change to attenuate the incoming audio. Please see page 13 for more information.
- ? **I have my new innkeeper LTD connected to the phone jack in my office. Why does it keep dropping the calls as soon as I try to connect it?**
- ! The telephone jack in your office is very likely for a multi-line phone system. The jack may look like a standard phone jack, but it is wired differently and may carry voltage on different pins which could cause serious damage to your hybrid. Innkeeper LTD should only be connected to a single, analog phone line. Check with the telephone specialist in your building for the possibility of getting an analog line for your innkeeper LTD.
- ? **My innkeeper LTD is connected to an analog line at my office location, and will auto-answer an incoming call. Why won't it auto-disconnect at the end of the call?**
- ! A PBX phone system can be programmed to provide an analog line. Check with the telephone specialist in your building for the possibility of resetting the characteristics of your analog line to provide an appropriate CPC disconnect signal.

Operation

Remote Control Jack

The RJ-45 jack on the back of the innkeeper LTD provides connection to a JK Audio Guest Module 1* remote control device, or it can be wired to the switch contacts on your broadcast console. Do not connect this jack to the network port on your computer.

RJ-45 Pinout:

- Pin 1: Ground
- Pin 2: Call / Drop Control (main control pin)
- Pin 3: Ring / OH LED
- Pin 4: DTMF Input
- Pin 5: +4.3 VDC
- Pin 6: Reserved
- Pin 7: Reserved
- Pin 8: Reserved

Momentarily connect pin 2 to pin 5 (power) through a 100 ohm 1/4 watt resistor to take innkeeper LTD off-hook.

Momentarily connect pin 2 to pin 1 (ground) through a 100 ohm 1/4 watt resistor to release (Drop) the phone line.

Pin 3 contains a 4.3 VDC, 40 mA current limited output to drive a signal LED. We suggest adding a 200 ohm 1/4w resistor in series with an LED connected to ground.

Pin 5 supply output is current limited to 100 mA with a resettable fuse for use with the Guest Module and pin 2 connections. Do not attempt to power additional circuitry from this pin.

Guest Module 1*

This convenient device gives you remote access to the on-hook / off-hook and dial features of the innkeeper LTD. The Call button will flicker when a call comes in and stay lit while a call is present. When you dial out using the Guest Module 1 keypad, tones are sent directly down the phone line, and do not come back mixed with the Caller audio. This device can be used to send DTMF tones to digital phone services such as a conference bridge without the tones being recorded.

* Contact your JK Audio dealer for more information on this optional accessory.

Connection

Connecting Cables

Although each application will require a slightly different setup, there are some cables that everyone can agree upon:

1. Phone Line - Connect the supplied RJ-11 phone line cable between the jack marked "Line" and your wall jack. Be sure this jack can support standard single-line analog telephone operation.
2. Send Audio - Connect a line level audio signal from the output of your other equipment such as a mixing console or PA system, to the XLR Send jack on the innkeeper LTD.
3. Caller Audio - Connect the Caller output jack to a line level input on your mixing console or other equipment.
4. Power - Connect the supplied AC power cord to the back of the innkeeper LTD and then to an AC power outlet.



This device should be connected to an adequate surge protective device at all times both for the power connector and for the telephone line to avoid damage from lightning or electrical surges.

Your innkeeper LTD is now ready to take calls. You may want to connect an auxiliary phone to the innkeeper for call setup, or you can simply use Auto-Answer or the Call button to answer an incoming call.

Studio Mix-Minus Setup

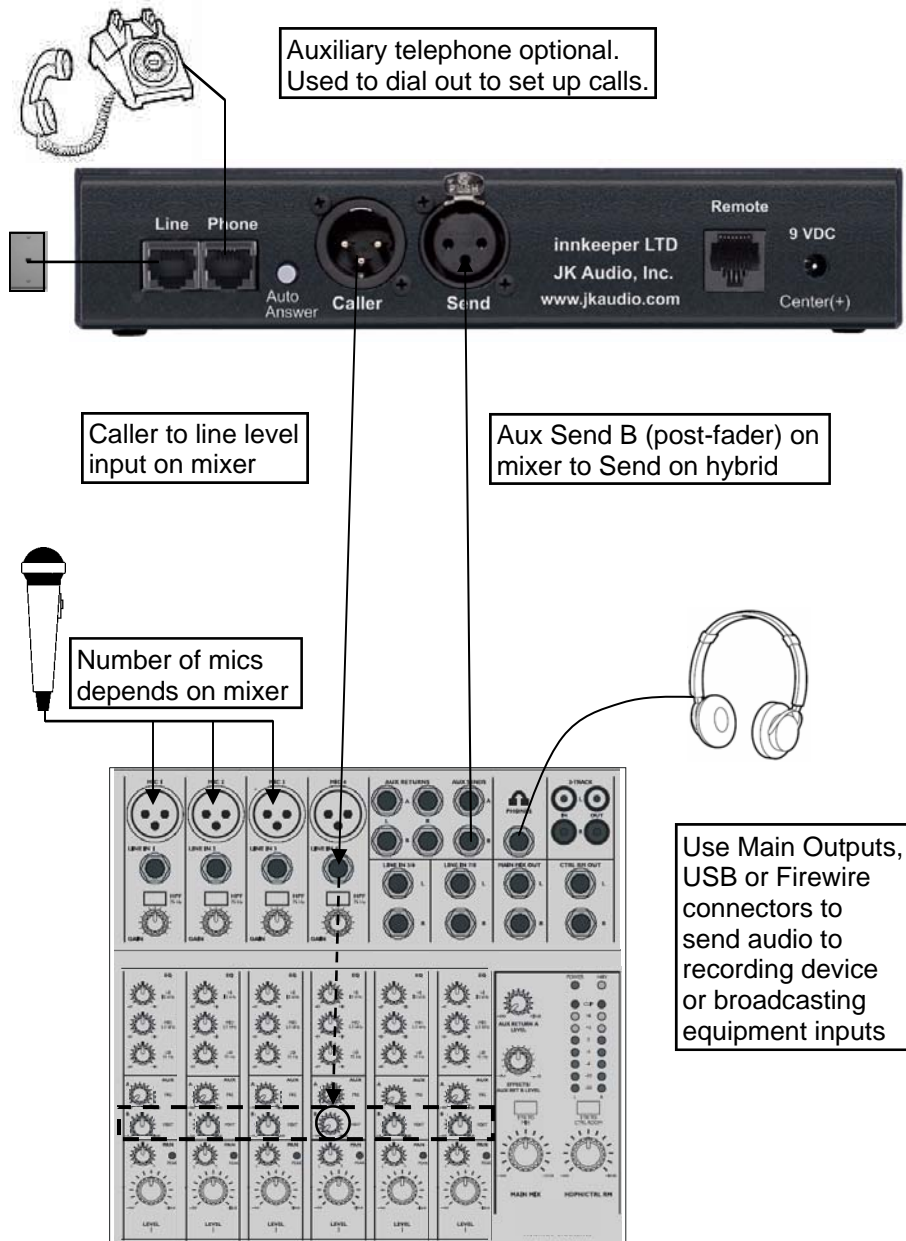

Figure 3: Studio Mix-Minus Setup

Operation

Auxiliary Telephone

An auxiliary telephone provides you with an easy way to dial out or set up your calls. Innkeeper LTD will disconnect the auxiliary telephone when you press the Call button. If you need to take the call back on the aux telephone, simply pick up the telephone handset before the innkeeper LTD's Drop button is pressed.

To use an auxiliary phone equipped with a "Hold" feature to place or screen a call, first set up the call and place the call on hold. When you are ready to take the call on innkeeper LTD, press the Call button and your telephone will automatically release the hold.

Your phone will operate as a normal telephone anytime you are in Drop mode. Leaving the hybrid connected between the wall jack and your telephone will not affect normal use of your phone. Audio will only pass through the hybrid when you press the Call button.

Optional Jumper Settings

If the incoming Caller level is too high and peaking the red -3 dB LED, you may need to change the setting of an internal jumper. Disconnect power from the hybrid and remove the cover of the innkeeper LTD to locate Jumper 1. This blue jumper should be close to the center of the circuit board with a label printed on the board. The default position for this jumper is closed (covering both pins). Changing the jumper to the open position (either remove the jumper or cover just one pin) will provide 6 dB attenuation of the incoming audio signal.

Auto-Answer

The Auto-Answer feature will answer on the first ring. When Auto-Answer is enabled, you can still make calls manually using the Call button. When finished, you can either drop the call manually or allow the call to Auto-Disconnect. Innkeeper LTD will look for a CPC disconnect signal from the phone company to determine when a call has disconnected. This can take up to a minute.

PA System Setup

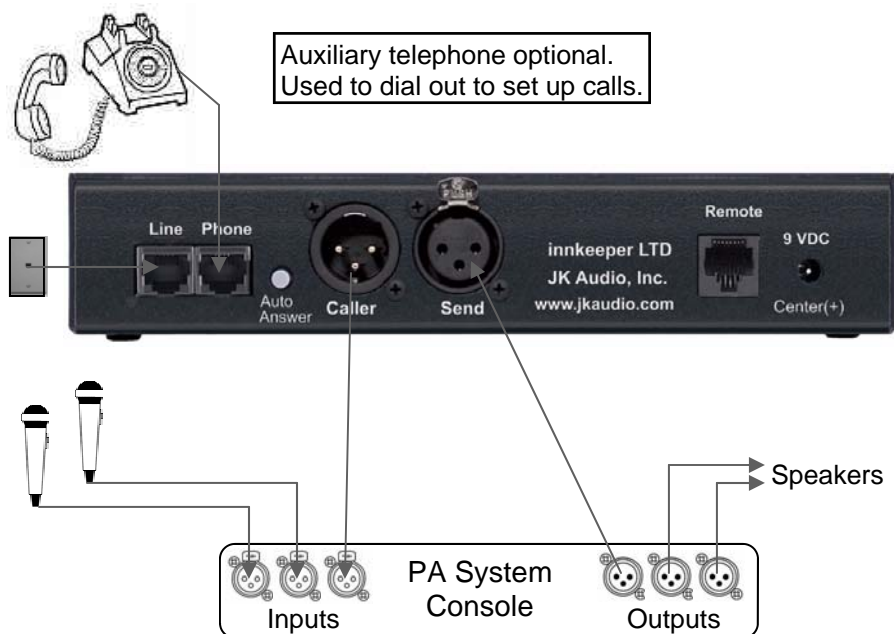

Figure 5: PA System Setup

Alternative to Mix-Minus Setup

If your mixer does not have an Aux Send bus, you can achieve the same results using Pan controls with the Left and Right outputs. Simply pan the Caller to the Right output. Then connect only the Left output to the innkeeper LTD Send XLR. This signal should contain all inputs except the Caller. Or, you may use an external Mix-Minus device that will create this signal for you.

Studio Mix-Minus Setup

Following the instructions in the owner's manual for your audio mixer, connect your microphones, headphones and recording device and set the levels on your mixer.

On the front of the innkeeper LTD, set the Send and Caller volume controls to center.

To connect the innkeeper LTD to your mixer, use a balanced female XLR cable with an adapter if necessary (not included) to connect the Caller jack on the back of the innkeeper LTD to any unused Line input on the mixer. Using a balanced XLR male to 1/4" cable (not included), connect the Post-Fader Aux bus output (Aux Send B on this mixer diagram) to the Send XLR input on the innkeeper LTD.

On your mixer, locate the row of Aux B knobs. This row of knobs will set the level of each input channel to the Aux B output which is sent to the phone caller. Turn all of these knobs to 9 o'clock except for the channel you have the Caller from the innkeeper LTD connected to (Channel 4 in this example). This Aux B knob should be set fully off (hard left on most mixers).

Speak into your microphone and watch the level indicators on the mixer. Adjust your Mic Level so your audio is at 0 dB on the meter most of the time and occasionally up to +3 dB. Repeat for each mic.

Next check the Send level meter on the front of the innkeeper LTD. Adjust the Send volume control on the innkeeper LTD so that both green lights are on while you speak, and you only occasionally see the red light. Some mixers may have an Aux Send master control that will affect the audio level you send to the innkeeper LTD. You should start with this knob at 12 o'clock and adjust it if necessary to get the correct level on the innkeeper LTD.

Next set up a call on your phone line. Press the Call button on the front of the innkeeper LTD. As the Caller speaks, adjust the Gain knob on the mixer for the channel you have the Caller audio connected to (Channel 4 on this diagram) until the Peak light for that channel comes on, then reduce the level slightly just until the light goes out.

Now you are ready to go. These settings should work for most phone calls.

Mix-Minus Explanations

Why do I need a Mix-Minus Setup?

Mix-minus is an audio signal that is designed to avoid feedback and echo in a conference or telephone interface application. When connecting a phone hybrid to a mixing console, the caller's audio will be connected to an input channel on the mixer along with all the microphones, music, etc. All of these inputs combine to create the Master mix to be sent to your broadcast, recording device, or the speakers of your PA system. However, if you connect this Master mix to the input of the hybrid, you are also sending the caller's own audio back to the caller. This completes a feedback loop and creates a strange and annoying echo. That is why it is important to create a special mix that contains a mix of all the microphones, music, etc., "Minus" the caller's audio.

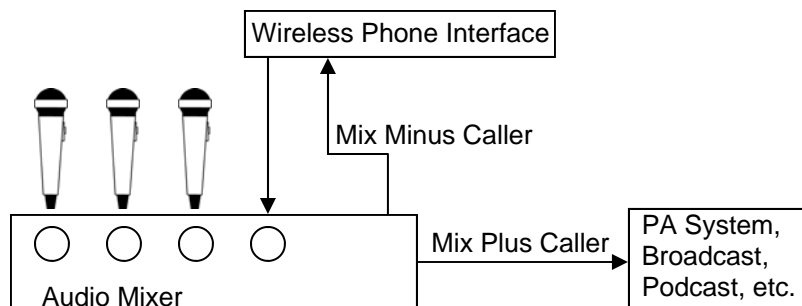

Which Mix-Minus Setup Should I Use?

Most radio stations and recording studios should use the Studio Setup shown on pages 8-9. Using an Aux Send output that is Post Fader will keep the audio that is being sent out to the caller tied to the same output you send to your broadcast or PA system. This way your sound engineer can more easily control each channel. During a station break, the talent microphones can be muted simply by turning off the output level knob or slider and their audio will not be sent to the broadcast or to the caller.

If you have a small studio and you use your wireless phone hybrid to record interviews, you might consider using the Simple Setup on page 11. When the Aux Send output is Pre Fader, the levels you set on the Aux Send controls will only affect what the Caller hears, and the levels you set at the output faders will only affect the recording or broadcast. If the talent wants to be able to talk to the caller during station breaks, this is the setup you should use, although the talent would need to connect their headphones to the hybrid instead of to the mixer. You should also use this setup if you want to be able to send music or sound effects to the broadcast that the caller will not hear.

Simple Setup for Mixer

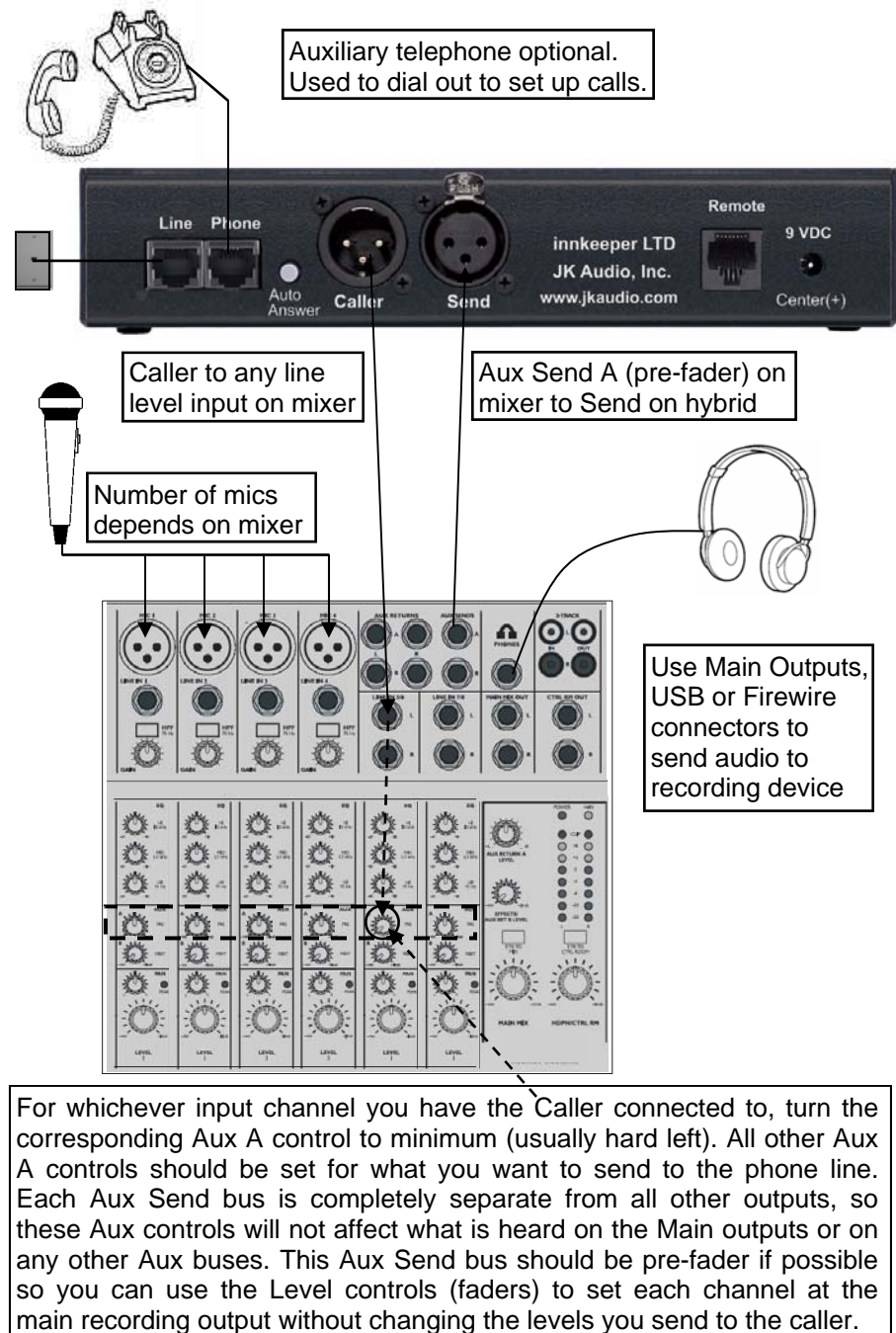

Figure 4: Simple Setup for Mixer