



RemoteMix 4 CE PORTABLE BROADCAST MIXER

FEATURES

- Four XLR mic inputs
- Switchable 48 volt phantom power on each mic input
- Mic/Line pad on channels 3 & 4
- One 3.5 mm line level input
- ¼" Line level headphone cue input
- PBX handset interface
- 2.5 mm cell phone interface
- Bluetooth Wireless Technology
- Dual 9V battery drawers
- Four ¼" headphone output jacks
- Separate headphone level controls
- Separate headphone source selection
- Male XLR line level mixer output
- 3.5mm stereo output
- Phone line jack with hook-switch and ringer LED
- DTMF keypad with redial
- 100-240 VAC power supply included

RemoteMix 4 is a four channel field mixer combined with a four channel headphone amplifier. Includes a phone line hybrid and keypad, as well as a universal PBX handset interface and a 2.5 mm wireless phone interface. It can also connect to cell phones and portables using *Bluetooth* Wireless Technology. All this in a tough, portable unit that's smaller than a lunch box. All-in-one is an understatement. These parts were designed to work together and save setup time in the field. No need to send an engineer with patch cables. All the pieces work together in one reliable unit.

Radio - RemoteMix 4 was designed for live remotes. Use it as a phone line hybrid, calling into your studio talk show hybrid. Use it as a front end mixer for your POTS, ISDN or IP codec. Use it with your laptop codec.

TV – RemoteMix 4 gives you the ultimate phone connectivity with four IFB feeds. Imagine being able to send and receive interview audio, and pull IFB out of any business phone system, even your cell phone. More than a field mixer, this is a shoot saver.

RemoteMix 4 PORTABLE BROADCAST MIXER

Great Sound - A soft limiter prevents overdriving the phone line interfaces, while the mixer XLR output is pre-limiter (full range). Bass Boost adds some low end before sending the signal down the phone line. Convenient 3.5 mm send and receive jacks for recording the show, or mixing in your MP3 player.

Bluetooth Wireless Technology - RemoteMix 4 will first attempt to connect in hands free mode to a cell phone. If this type of connection is not available, it will connect to any other product, such as a notebook or portable that allows a *Bluetooth* wireless connection. This wireless headphone mode offers a full audio bandwidth stereo connection.

Power Smart Design - Phantom power is not always needed, yet it can be a real drain on batteries. The phantom power generator only runs if any of the rear panel 48 V switches are set to "ON". Low noise, lowpower ICs are used throughout to preserve battery life. The low noise 100-240 VAC desktop style powersupply (included) overrides the battery power only when the supply is actually providing power. If the power goes out, the batteries automatically cut in.

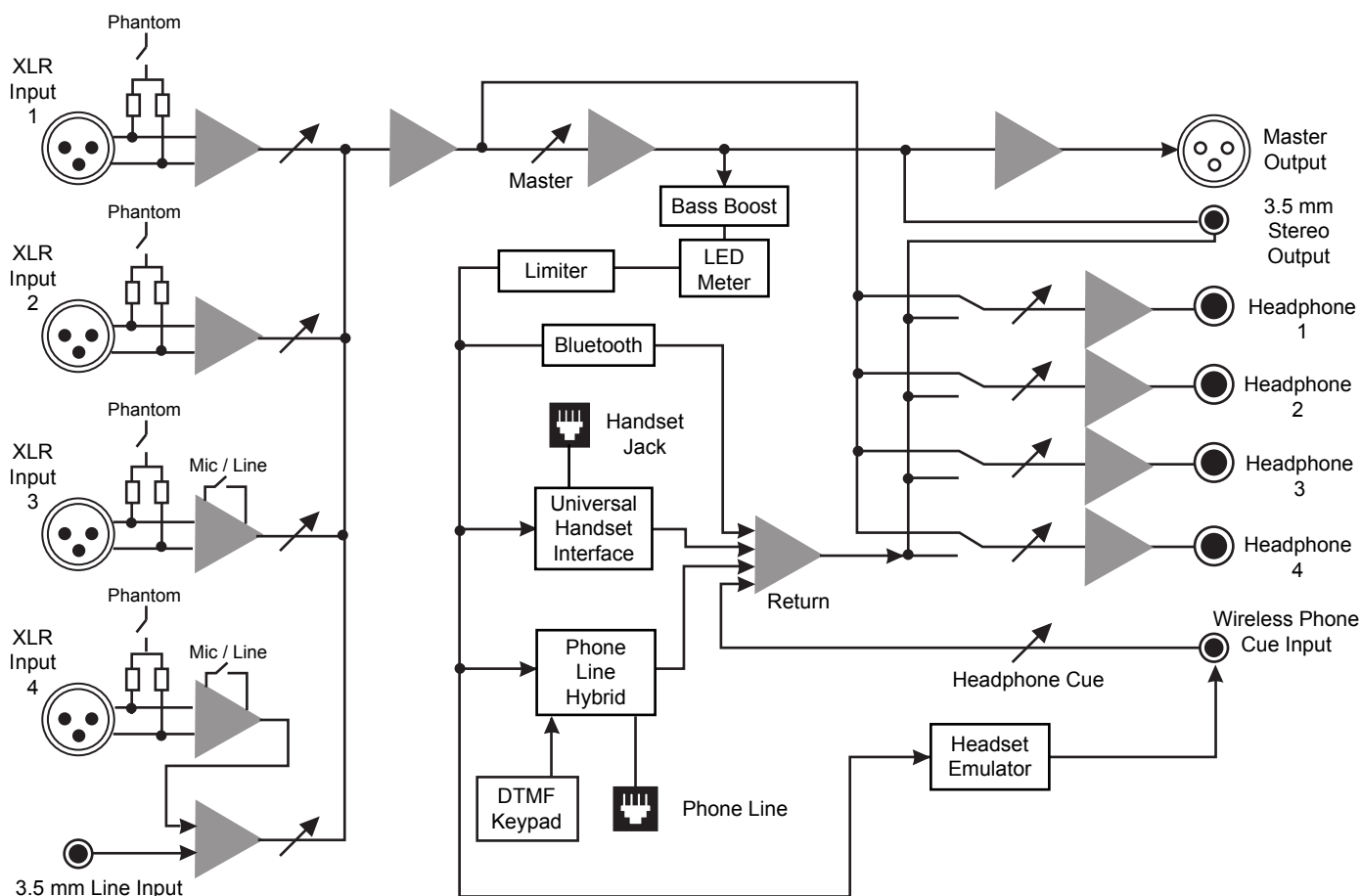

RemoteMix 4

PORTABLE BROADCAST MIXER



Rear view

Specifications

	Input	
	Impedence	Level
Female XLR (4) Mics	2 k ohms	-25 dBu nom
1/8" (3.5mm) Stereo Line	20 k ohms	-10 dBm nom
Headphone Cue 1/4"	20 k ohms	-10 dBu nom
Output		
Balanced Male XLR	50 ohms	+16 dBu max 20 Hz - 20 kHz +/- 1dB
1/8" (3.5mm) Stereo	100 ohms	-10 dBu nom
Headphone 1/4" Stereo	8 ohms	1/3 watt per channel

Channel 3&4 have -40 dB Mic/ Line pad switch
Line = +16 dBu max, 50k ohms

Phone Line Connector:	RJ11C	Wireless Phone:	36" cable provided with 2.5 mm 3-conductor headset plug
Isolation:	1500 VAC	Bluetooth:	Frequency Response Headset: 300Hz - 3400Hz Headphone Mode: 30Hz - 17kHz
Ringer:	0.5B REN		Power:
PBX interface:	RJ22	Weight:	3.8 lbs
Size:	9.5" x 8" x 3"		

The *Bluetooth* word mark and logos are owned by the *Bluetooth* SIG, Inc. and any use of such marks by JK Audio, Inc. is under license. Other trademarks and trade names are those of their respective owners.