

## PS 125 • Installation Guide



### Introduction

The Extron PS 125 is a high performance, 60W, 12 VDC power supply. The auto-switchable 100 VAC to 240 VAC input can supply a maximum current of 5 amps for up to eight outputs. Each DC output is on a two-pole captive screw connector, with no per-output current limitation. Two-tone LEDs on the front and rear panels indicate normal operation (green) and overload condition (red).

The rack mountable PS 125 has a 1U high, quarter rack wide, 8.5 inches deep metal enclosure, allowing the PS 125 to take advantage of a variety of mounting options (see [Mounting the PS 125](#) (see page 3).

### FCC Class B Notice

This equipment has been tested and found to comply with the limits for a Class B digital device, pursuant to part 15 of the FCC rules. These limits provide reasonable protection against harmful interference in a residential installation. This equipment generates, uses, and can radiate radio frequency energy and, if not installed and used in accordance with the instructions, may cause harmful interference to radio communications. There is no guarantee that interference will not occur. If this equipment does cause interference to radio or television reception, which can be determined by turning the equipment off and on, you are encouraged to try to correct the interference by one or more of the following measures:

- Reorient or relocate the receiving antenna.
- Increase the separation between the equipment and receiver.
- Connect the equipment into an outlet on a circuit different from that to which the receiver is connected.
- Consult the dealer or an experienced radio/TV technician for help.

In order to maintain compliance with FCC regulations, shielded cables must be used with this equipment. Operation with non-approved equipment or unshielded cables is likely to result in interference to radio and TV reception. The user is cautioned that changes and modifications made to the equipment without the approval of the manufacturer could void the user's authority to operate this equipment.

**NOTE:** This unit was tested with shielded I/O cables on the peripheral devices. Shielded cables must be used to ensure compliance with FCC emissions limits.

For information on safety guidelines, regulatory compliances, EMI/EMF compatibility, accessibility, and related topics, see the [Extron Safety and Regulatory Compliance Guide](#) on the Extron website.

### Front and Rear Panel Features

All power and output connections are on the rear panel.

- 1 Power Status LEDs
- 2 Overload LED
- 3 IEC Connector/Power Supply
- 4 DC Output Connectors

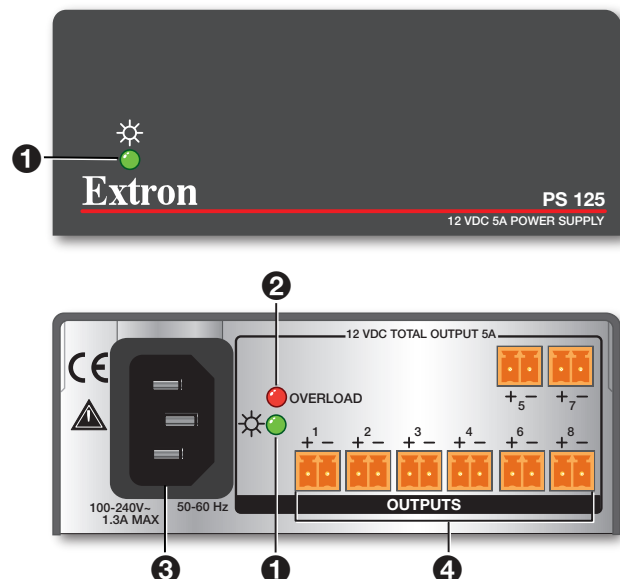

Figure 1. PS 125 Front and Rear Panels

## LED indicators

- 1 **Power Status LEDs** — (see [figure 1](#) on the previous page) These front and rear panel LEDs indicate the PS 125 status by lighting **Green** when power is applied and current draw is normal.
- 2 **Overload LED** — lights **Red** to indicate a current overload condition or when an output is shorted.

### ATTENTION:

- Continued operation in an overload condition may cause premature power supply failure.
- Un fonctionnement ininterrompu en situation de surcharge peut entraîner la défaillance prématurée de la source d'alimentation.

**NOTE:** To identify the shorted output, unplug the outputs one at a time until the Overload LED lights off.

## Input Power

Apply power to the PS 125 using the supplied IEC power cord.

- 3 **IEC Connector/Power Supply** — Plug one end of an IEC cord into this connector and the other end into a 100-240 VAC source.

## DC Outputs

- 4 **DC Output Connectors** — Connect the power cables from devices that will receive power from the PS 125 to these 3.5 mm captive screw connectors.

The PS 125 supports up to eight power supply outputs. For details on limitations and how to wire these captive screw connectors, see [Output Power – Wiring the DC Output Connectors](#) on page 3.

## Connections

### Input Power – Using the IEC Power Cord

Use the included IEC power cord to connect the PS 125 to a 100 VAC to 240 VAC, 50-60 Hz power source.

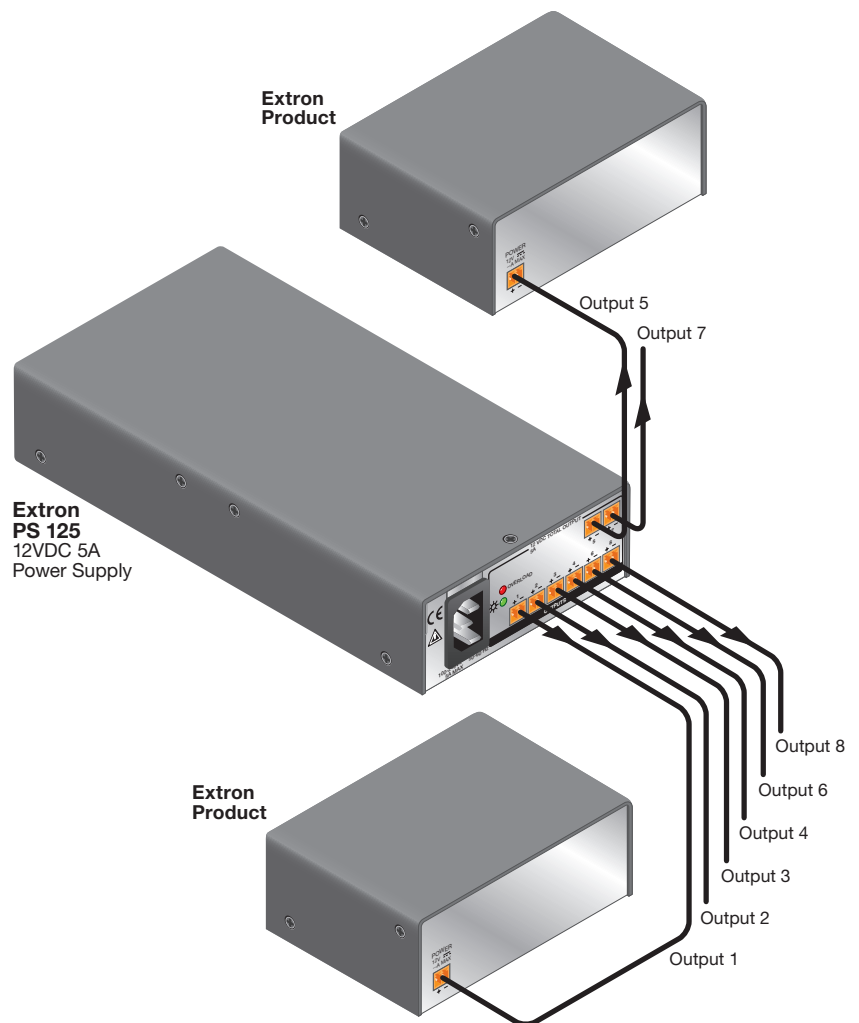

**Figure 2.** PS 125 Application Diagram

### ATTENTION:

- For permanently connected equipment, there must be a readily accessible disconnect device incorporated in the building installation wiring.
- Pour les équipements branchés en permanence, un dispositif d'isolement rapidement accessible doit être intégré à l'installation électrique du bâtiment.
- The circuit breaker used for this connection should be rated 20 amps maximum.
- Le disjoncteur utilisé pour cette connexion doit avoir une tension nominale de 20 A max.

# PS 125 • Installation Guide (Continued)

## Output Power — Wiring the DC Output Connectors

The PS 125 can supply 12 VDC to multiple devices using 3.5 mm, 2-pole captive screw connectors. The combined current draw of the connected devices must not exceed 4 amps.

### ATTENTION:

- To verify proper polarity before connection to a device, plug in the power supply with no load and check the output polarity with a voltmeter. Remove power before wiring.
- Pour vérifier la polarité avant la connexion, brancher l'alimentation hors charge et mesurer sa sortie avec un voltmètre. Couper l'alimentation avant de faire l'installation électrique.
- Ensure that you observe correct wire polarity. The two power cord wires must be kept separate while the power supply is plugged in.
- Assurez-vous de respecter la polarité correcte du câble. Les deux cordons d'alimentation doivent être maintenus à l'écart tant que la source d'alimentation est branchée.

To connect products to the outputs of the PS 125:

1. Cut the DC output cord to the length required.
2. Strip the jacket of the conductor wire (see figure 3 on the right).

### ATTENTION:

- The length of the exposed wires in the stripping process is **critical**. The ideal length is 3/16 inches (5 mm). Any longer and the exposed wires may touch, causing a short circuit. Any shorter and the wires can be easily pulled out even if tightly fastened by the captive screws.
- La longueur des câbles exposés est **primordiale** lorsque l'on entreprend de les dénuder. La longueur idéale est de 5 mm (3/16 inches). S'ils sont trop longs, les câbles exposés pourraient se toucher et provoquer un court-circuit. S'ils sont trop courts, ils peuvent être tirés facilement, même s'ils sont correctement serrés par les borniers à vis.
- Do not tin the stripped power supply leads before installing the captive screw connector. Tinned wires are not as secure in the captive screw terminals and could pull out.
- Les câbles étamés ne sont pas aussi bien fixés dans les borniers à vis et pourraient s'arracher. Ne pas étamer le câble d'alimentation dénudé avant d'avoir installé le bornier à vis.

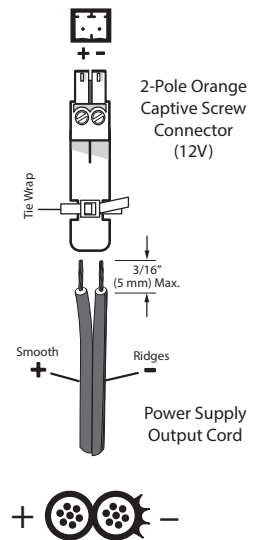

**Figure 3. DC Output Wiring**

3. Slide the leads into the supplied 2-pole captive screw plug and secure them using an Extron Tweezer or small screwdriver.
4. Use the supplied tie wrap to strap the power cord to the extended tail of the connector.

## Mounting the PS 125

There are several optional accessories for mounting the PS 125 (see the mounting options at [www.extron.com](http://www.extron.com)).

### UL Rack Mounting Guidelines

The following Underwriters Laboratories (UL) guidelines pertain to the installation of the PS 125 into a rack.

- **Elevated operating ambient temperature** — If installed in a closed or multi-unit rack assembly, the operating ambient temperature of the rack environment may be greater than room ambient. Therefore, consider installing the equipment in an environment compatible with the maximum ambient temperature specified by Extron (T<sub>ma</sub> = +32 to +122 °F [0 to +50 °C]).
- **Reduced air flow** — Installation of the equipment in a rack should be such that the amount of air flow required for safe operation of the equipment is not compromised.
- **Mechanical loading** — Mounting of the equipment in the rack should be such that a hazardous condition is not achieved due to uneven mechanical loading.
- **Circuit overloading** — Consideration should be given to the connection of the equipment to the supply circuit and the effect that overloading of the circuits might have on overcurrent protection and supply wiring. Appropriate consideration of equipment nameplate ratings should be used when addressing this concern.
- **Reliable earthing (grounding)** — Reliable earthing of rack-mounted equipment should be maintained. Particular attention should be given to supply connections other than direct connections to the branch circuit (such as the use of power strips).

## Rack Mounting

For optional rack mounting, mount up to four PS 125 power supplies on a Universal Rack Shelf (see figure 4. For more rack mounting options, go to [www.extron.com](http://www.extron.com)).

1. Remove any rubber feet from the PS 125.
2. Mount the PS 125 on the rack shelf, using two 4-40 x 3/16 inch screws in opposite (diagonal) corners.
3. If necessary, mount the half-rack width false front panel (included with the Universal Rack Shelf only) and the quarter-rack width false front panel (included with the PS 125) to the shelf, using two 4-40 x 3/16 inch screws in the front holes for each panel.

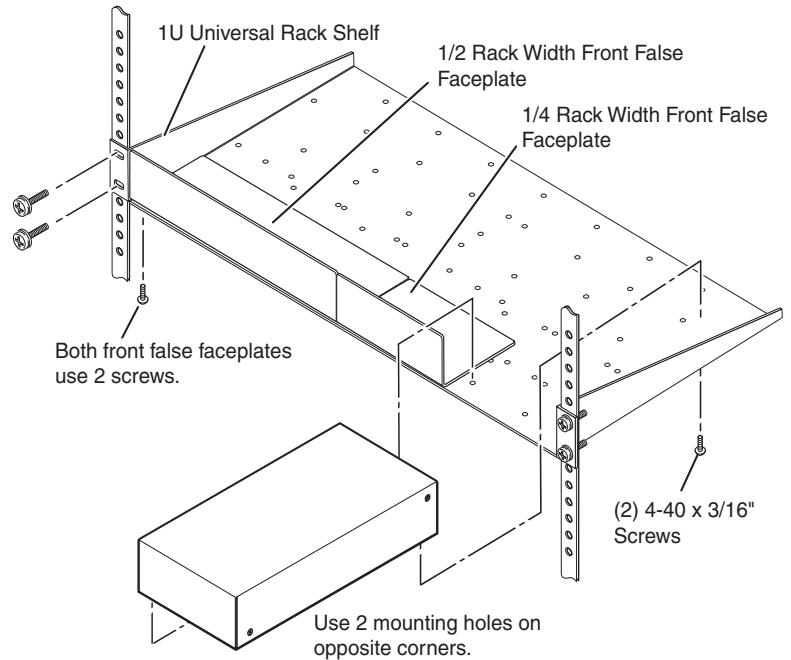

Figure 4. Rack Mounting the PS 125

## Under-desk Mounting

In addition to using the PS 125 power supply on a rack, it can also be mounted under furniture (such as a desk) using an optional under-desk mounting kit, MBU 125 (70-077-01) (see under-desk mounting options at [www.extron.com](http://www.extron.com)).

To mount the PS 125 under a desk or other furniture, follow these steps:

1. Attach the mounting brackets to the power supply with the provided machine screws (see figure 5).
2. Hold the power supply with the attached brackets against the underside of the furniture. Mark the location of the screw holes of the bracket on the mounting surface.
3. Drill 3/32 inch (2 mm) diameter pilot holes, 1/4 inch (6.3 mm) deep in the mounting surface at the marked screw locations.
4. Insert #8 wood screws into the four pilot holes. Tighten each screw into the mounting surface until just less than 1/4 inch of the screw head protrudes.
5. Align the mounting screws with the slots in the brackets and place the power supply against the surface, with the screws through the bracket slots.
6. Slide the unit slightly forward or back, then tighten all four screws to secure it in place.

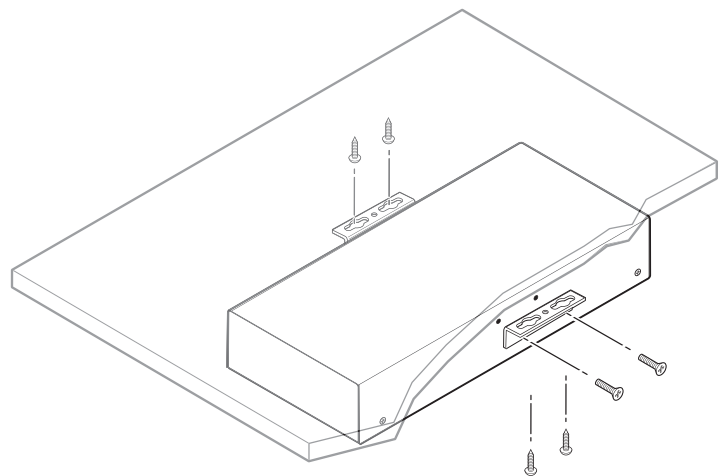

Figure 5. Under-desk Mounting the PS 125

# PS 125 • Installation Guide (Continued)

## ZipClip® Mounting

The PS 125 can be mounted under a desk, onto a wall, or other furniture using the ZipClip 200 or 400. (See ZipClip mounting options at [www.extron.com](http://www.extron.com)).

### ZipClip 200 and ZipCaddy 200 Mounting Installation

1. Mount the ZipClip 200 to an under-desk mounting surface or to a rack rail using the four included mounting screws.

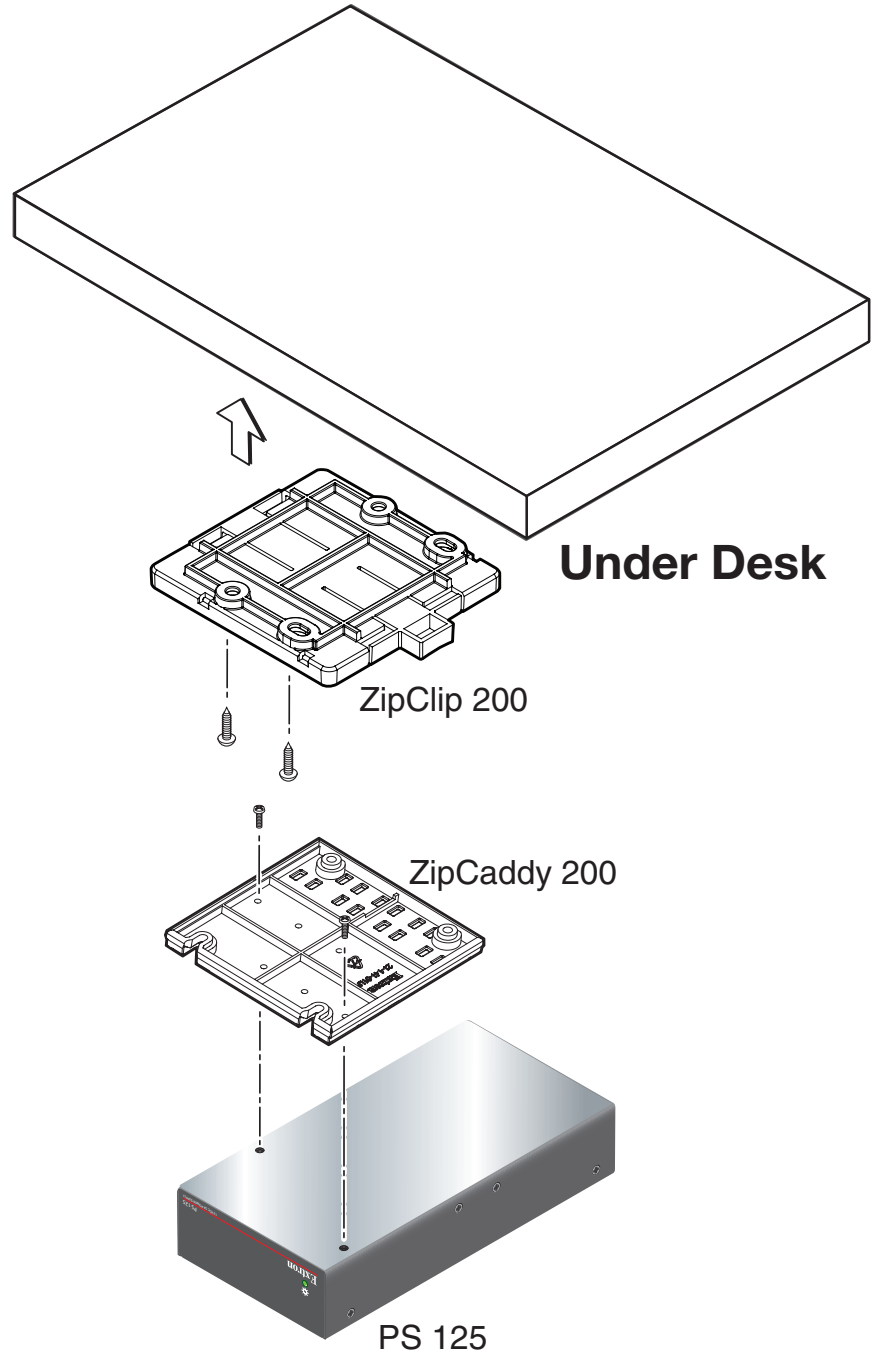

2. Mount the PS 125 to the ZipCaddy 200. Two screws attach the plate to the bottom of the unit. The mounting holes on the PS 125 align with the mounting holes on the plate.

Figure 6. Under-desk Mounting

The caddy-mounted PS 125 can now be quickly and conveniently attached and detached from the mounting location, via the quick-release tab.

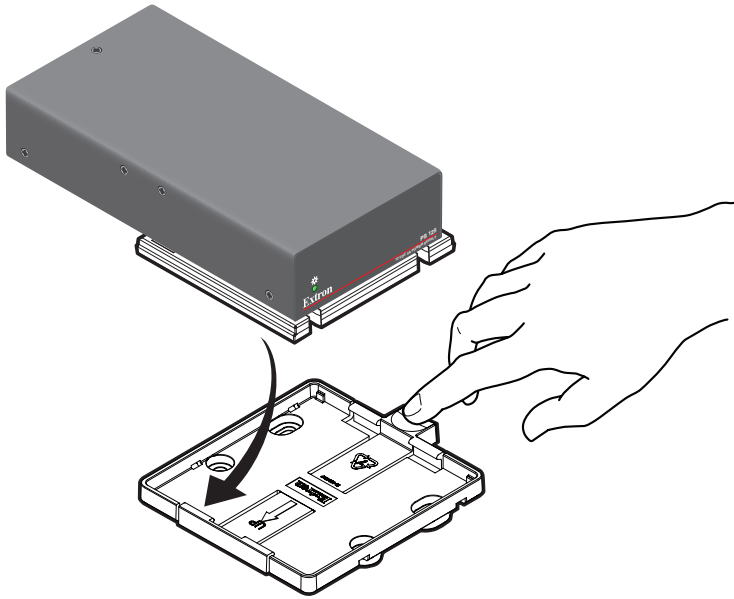

**Figure 7. Easy Attach and Release**

For information on safety guidelines, regulatory compliances, EMI/EMF compatibility, accessibility, and related topics, see the [Extron Safety and Regulatory Compliance Guide](#) on the Extron website.